

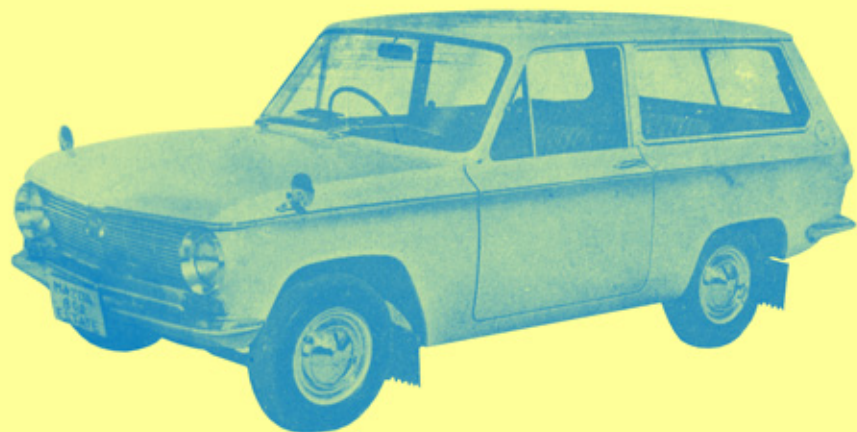

MAZDA 800 ESTATE

OPERATION MANUAL





The Mazda 800 ESTATE is manufactured with the use of the latest facilities and highest technique, we are confident that its modern style and high performance will fully satisfy the expectations of vehicle operators.

Though utmost consideration to various road conditions and economic situations has been made for this car, the life of the vehicle depends largely upon the proper maintenance and operation by users. Accordingly, it is recommended that this instruction book be carefully read in order to operate this vehicle and make the most of its merits.

If any faulty point is noted in this vehicle, please call immediately on the local MAZDA sales dealer for inspection, so ensure the utmost satisfaction from this vehicle in the years ahead.

CONTENTS

Specifications	1	Water level of radiator	12	Air cleaner.....	26
Description of the Mechanism	3	Supply of brake (clutch) fluid.....	12	Carburettor	27
Instrument panel	4	Battery	13	Adjustment of accelerating pump	27
Ignition-starting	4	Steering wheel	13	Electric fuel pump	28
Oil pressure warning lamp.....	5	Brake	13	Adjustment of valve tappets	28
Generator warning lamp.....	5	Gasoline supply	13	Cooling system	29
Fuel meter.....	5	Tire pressure.....	14	Fan belt	29
Water temperature indicator.....	5	Description of the mechanism	15	Battery maintenance	30
Direct Indicator Pilot Lamp	6	(DeJuxe)		Distributor	30
Choke button	6	Starting Engine	19	Spark plugs	31
Ash tray.....	6	Starting a cold engine	15	Electrical Wiring Diagram	32
Wiper Switch	6	Starting a warm engine	16	Specified Oil	33
Operating Mechanism	7	Starting a car	16	Engine oil	34
Operation your synchromesh		Cruising	17	Oil filter.....	34
Transmission	8	Hill climbing.....	17	Transmission oil	35
Direction indicator lever	9	Descending.....	17	Steering gear housing oil	36
Light switch lever	9	Reversing	18	Lubricating Points	37
Accelerator pedal	10	Stopping and parking	18	Care and Maintenance of Body	39
Brake pedal	10	Instructions during cold weather	18	Method of care.....	39
Clutch pedal	10	Instructions during hot weather	20	Method of maintenance	40
Hand brake lever	10	Breaking-in a new car.....	22	Water washing	41
Operating the Car	11	Economical driving	23	Trouble Indications	42
Check-up before starting	11	Periodic Inspection and Maintenance	25		
Oil supply	12				

SPECIFICATIONS

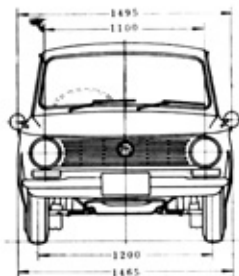
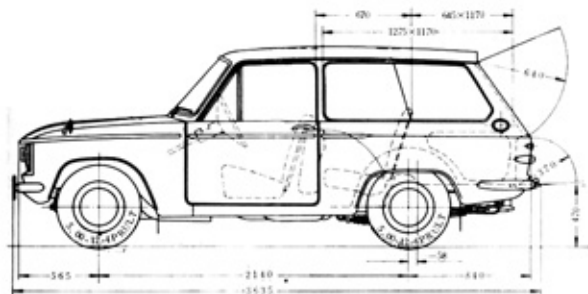

Engine

Type	4 cycle, O. H. V., water-cooled, 4 cylinders
Bore & Stroke	58mm (2.27in) × 74mm (2.90in)
Piston Displacement	782cc
Compression Ratio	8.5
Compression Pressure	9kg/cm ² (128lb/in ²) at 400r.p.m.
Brake Horsepower	42HP at 6,000r.p.m.
Maximum Torque	6kg-m (43.38 lb-ft.) at 3,200r.p.m.
Valve Clearance	0.2mm (0.008in)
Ignition Timing	16° before top dead center
Spark Plug	N.G.K. C-7HWB
Spark Gap	0.7mm (0.028in)
Distributor Point Gap	0.45mm (0.018in)
Carburettor	DCA-264-2A
Gas Valve Diameter	24mm (0.94in) 26mm (1.01in)
Venturi Diameter primary side	15mm (0.59in) × 5mm (0.19in)
Secondary side	20mm (0.78in) × 5mm (0.19in)
Lubricating System	Full-pressure System
Oil Pan Capacity	3.5 liter (0.92 U.S. gallon)
Cooling System	Forced Water Cooling
Battery	12V 32AH (20HR)
Generator	AC 250/12CR
Starting Motor	Nihon Denso
Clutch	Single Dry Plate

Transmission

Type	Synchronesh and Selectivity		
Gear Ratio	1st	4.265	Top 1.000
	2nd	2.506	Rev 4.265
	3rd	1.562	
Transmission Oil	1.3 liter (0.28 U.S. Gallon)		
Rear Axle	1/2 Floating Type		
Final Reduction Ratio	4.625		

Chassis

Minimum Turning Radius	4.3m (14'0.99")
Front Suspension	Wish-bone Ball Joint Type
Toe-in	2~3mm (0.08~0.12in)
Camber	0°53'
Caster	2°57'
Tire Size (Front)	5.00-12-4 P.R. ULT
Tire Size (Rear)	5.00-12-4 P.R. ULT

Brake

Foot Brake	Hydraulic Internal Expanding on all 4 Wheels	
Hand Brake	Mechanical Internal Expanding on Rear Wheels	
Brake Drum Diameter	(Front)	200mm (7.86")
	(Rear)	200mm (7.86")
Hydraulic Master Cylinder Bore	19.05mm (0.75")	
Wheel Cylinder Bore (Front)		20.64mm (0.81")
	(Rear)	20.64mm (0.81")

Car Measurement and Weight

Overall Length	3,635mm (11'10.85")	
Overall Width	1,465mm (4'9.57")	
Overall Height	1,395mm (4'6.82")	
Minimum Road Clearance	160mm (6.29")	
Luggage Box Inside Length	1,275mm (4'2.10")	
Luggage Box Inside Width	1,170mm (3'9.98")	
Luggage Box Inside Height	905mm (2'11.56")	
Car Weight (No Load)	715kg (1,573 lb)	
Car Weight Distribution (Front)	365kg (803 lb)	
Car Weight Distribution (Rear)	350kg (770 lb)	
Total Car Weight (With Load)	1,225kg (2,695 lb) 990kg (2,178 lb)	
Total Car Weight Distribution (Front)	410kg (902 lb) 450kg (990 lb)	
Total Car Weight Distribution (Rear)	815kg (1,793 lb) 540kg (1,188 lb)	
Seating Capacity	2 (5)	
Standard Payload	400kg (880 lb)	
Tread (Front)		1,200mm (3'11.16")
	(Rear)	1,160mm (3'9.58")
Wheelbase	2,140mm (7'0.10")	
Overhang to Front End of Body	565mm (1'10.20")	
Overhang to Rear End of Body	840mm (2'9.01")	
Height of Center of Gravity	548mm (1'9.53")	

DESCRIPTION OF THE MECHANISM

Before taking the wheel, you should know the different controls and the meaning of the indicators on the instrument panel. This information is give by the illustration in this chapter.

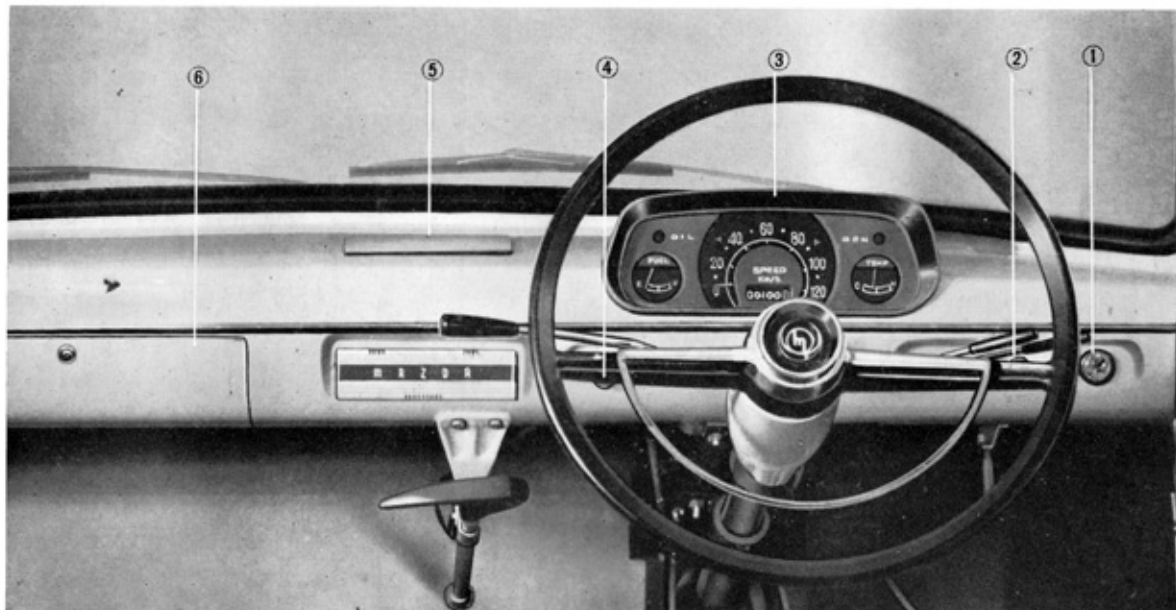

- ① Ignition-switch
- ② Windscreen wiper switch
- ③ Combination meter

- ④ Choke button
- ⑤ Ash-tray
- ⑥ Grove pocket

INSTRUMENT PANEL



- ① Speedometer
- ② Total mileage (kilometer) recorder
- ③ Oil pressure warning lamp
- ④ Generator warning lamp
- ⑤ Fuel meter
- ⑥ Water thermometer
- ⑦ Direction indicator lamp

Speedometer is calibrated to register miles per hour or kilometers per hour.

IGNITION SWITCH

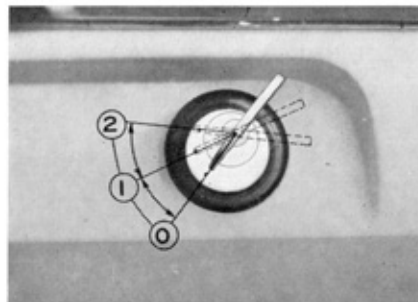

- ① Ignition off.
- ② Ignition on.
- ③ Starter.

To switch on ignition, turn the key until slight click is felt (pilot lamps will light up).

To operate the starting motor, turn the key fully (the resistance of a spring must be overcome) and release as soon as engine starts. The key is recalled to the "Ignition" position by a spring.

OIL PRESSURE WARNING LAMP

The oil pressure warning lamp glows when the ignition is switched on and is extinguished when oil pressure rises after the engine is in operation. This light should be off under normal condition but in case it should light up while the car is running, it is a warning that either the oil pressure is too low or that oil is leaking and should be checked into immediately to prevent damage.



GENERATOR WARNING LAMP

The generator warning lamp will light up when the ignition switch is turned on and will go off when the engine speed is increased and the generator begins to charge.

The charging condition is thus ascertained at a glance.

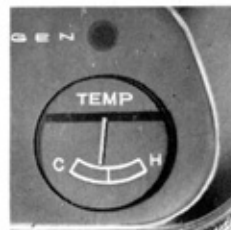

FUEL METER

The fuel meter indicates the approximate quantity of fuel in the tank when the ignition is switched on.

WATER TEMPERATURE INDICATOR

The water temperature indicator indicates the temperature of the engine coolant. The pointer should remain in the center of the scale in normal operation. If it moves to the extreme right, stop the engine immediately, then allow it to cool before examining the water level.

DIRECTION INDICATOR PILOT LAMP

The direction indicator lever actuates a switch which causes the indicator lamps on the front and rear of the vehicle and the green winker lamp to flash on and off. The pilot lamp indicates the operation of these lamps.

CHOKE BUTTON

By rulling the choke button the air sucked into the engine is controlled by the choke valve of the carburettor and enriches the gas mixture. This is a big help in starting the engine in cold weather or when the engine is cooled.

ASH-TRAY

The ash-tray in the driver's compartment is located at the center of the dash board, and in the rear compartment, 2 are installed on the right and left doors respectively. The ash-tray on the dash board can be released by pulling it out upwardly and the ones in the rear compartment by depressing the spring in the center of tray and pulling it to clean them out.

WIPER SWITCH (Standard)

Pull this switch to actuate the wiper motor under the condition of that the engine switch is being set to the first position, which will operate the blades to wipe the window. The wiper blades will automatically return to the original horizontal position and come to stop by pushing in the switch.

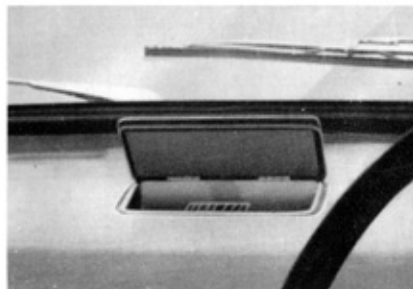

OPERATING MECHANISM

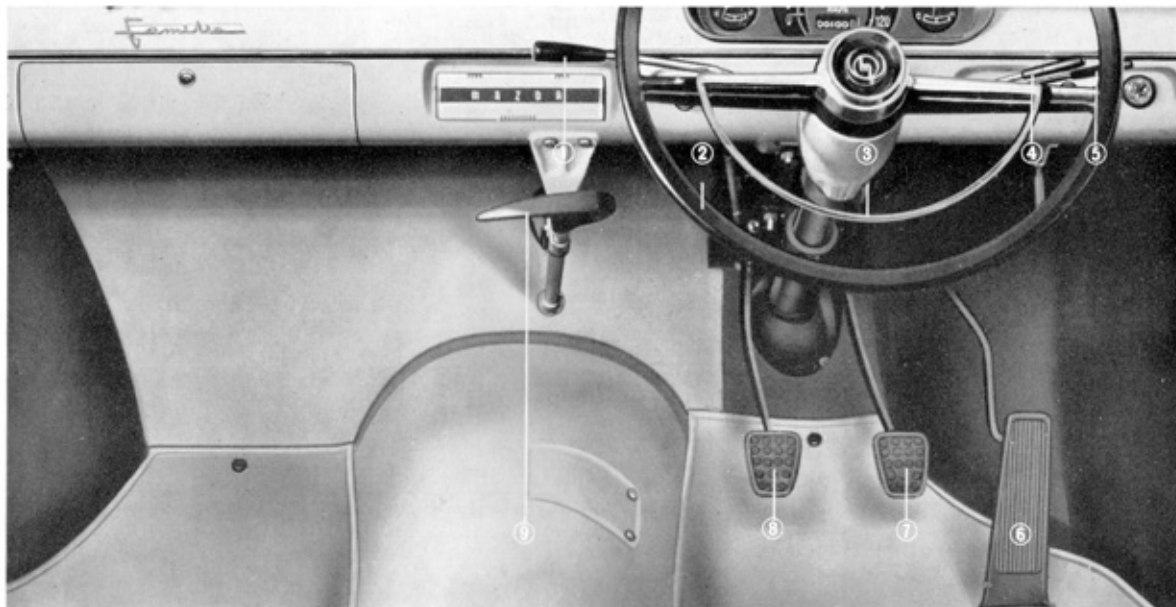

① Gearshift lever

② Steering wheel

③ Horn ring

④ Direction indicator lever

⑤ Light switch lever

⑥ Accelerator pedal

⑦ Brake pedal

⑧ Clutch pedal

⑨ Hand brake

OPERATION YOUR SYNCHRO-MESH TRANSMISSION



- Ⓝ Neutral
- ① Low Speed
- ② Second Speed
- ③ Third Speed
- ④ Top Speed
- ⑤ Reverse

The operation of the lever in engaging the gears consecutively is as follows :

See that the gearshift lever is in neutral position.

First Speed : With clutch pedal depressed, raise lever toward steering wheel and push upwards until it is fully engaged in first speed location ; then gradually release clutch pedal.

Second Speed : With clutch pedal depressed pull lever 'down until lever has reached to end of its travel into second speed position.

Third Speed : With clutch pedal depressed, push lever upwards from second position and then it is automatically returned to the neutral position and push it upwards, can easily engaged.

Top Seed : With clutch pedal depressed, pull lever downward across through neutral position and engage top speed position.

Reverse : With car at a standstill, depress clutch pedal, pull lever down and away from steering wheel.

Direction Indicator Lever

To operate the turn signal (Direction Indicator) lamps the ignition switch must first be in the "ON" position.

The direction Indicator switch lever, on the right of the steering column, is pushed UP for Left Turn and Down for Right Turn. Both the front and rear direction Indicator lamps will flash together according to the direction selected.

Light Switch Lever

Headlights, parking lights, passing lights, etc are controlled by a single three-position switch lever, located on the right of the steering column. The three positions of the lighting switch are as follows.

Position of Lever	Lights	Remarks
Horizontal	None	For Daylight
Down	Side Lamps, Tail Lamps	Night Parking
1 Step Up	Head (Small), Number, Tail Lamps	Night Passing
2 Steps Up	Head (Large), Number, Tail Lamps	Night Driving

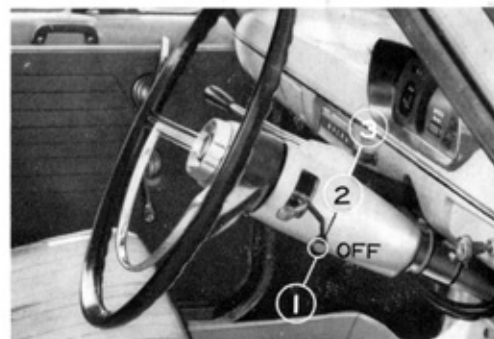

Accelerator Pedal

This pedal is connected with the carburettor and controls the engine speed, and by it the car speed is changed. It should be made a practice to depress the pedal gradually.

Brake Pedal

Depressing this pedal applies the four wheel hydraulic service brakes. The most important thing to remember about a hydraulic braking system is to maintain the fluid level in the reservoir. If the level is allowed to fall too low, air will get into the system and you will then have the trouble and expense of "bleeding" the system.

Clutch Pedal

By means of this control the power required in putting the car in motion may be gradually and smoothly applied to the drive system. When the clutch pedal is in its normal position, the clutch is engaged and the engine is directly connected to the transmission. By depressing the pedal, the clutch is released and the transmission, disconnected from the engine permitting the shifting of the transmission gear.

Hand Brake Lever

Pulling this lever upward will permit the brake to be applied mechanically to the two rear wheels. Keep this lever pulled up during parking and always remember to release it by turning it to the left once and then pushing it down when driving off.



OPERATING THE CAR

Check-up before Starting

Before starting the engine, it is necessary to make a check on the following point.



OIL SUPPLY

The oil supply is measured by the oil level when the vehicle is placed horizontal. The upper line F on the dip-stick gauge indicates 3.5 liter and the lower line L indicates 2.3 liter. It is advisable to have the oil level between line F and L at all times. Be sure that the oil level stays within the red marking and that oil is not mixed with water. As insufficient oil supply causes heating or wear, it is important to check the oil.

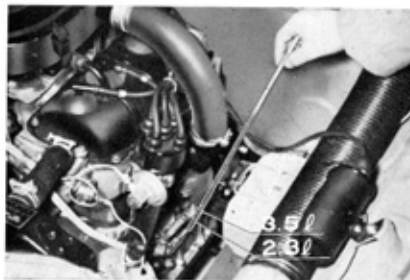

WATER LEVEL OF RADIATOR

Check whether the water level can be noted from the filter neck and whether there is any leakage. Insufficient coolant overheats the engine.



SUPPLY OF BRAKE (CLUTCH) FLUID

The reserve tank should always have more than 2/3 of fluid.

BRAKE FLUID PIPE

Check for loose joints in the brake fluid pipe to prevent fluid leakage. Fluid leakage would cause the brake not to work, which will involve you in an accident.

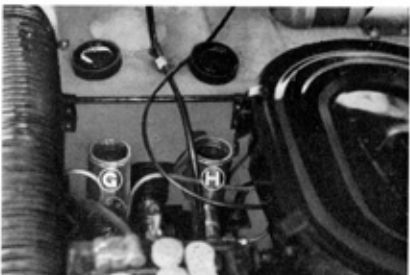

BATTERY

To prevent corrosion and leakage of current, keep the top of your battery clean and dry. Also keep the terminals clean and well covered petroleum jelly. The life of the battery will be prolonged if the electrolyte is maintained level with the top of the separators of necessary, add distilled water weekly in hot weather and every two weeks during the winter months.

STEERING-WHEEL

Shake the steering-wheel up and down and sideways. If there is too much play, smooth and fast operation of the steering-wheel cannot be obtained. The proper play in turning direction is about 30 mm.

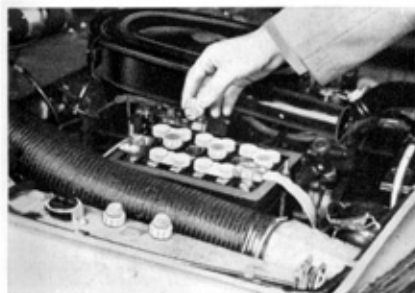

BRAKE

The brake is one of the most important mechanism for safe driving. In addition to daily inspection, constant care should be taken while driving. Even when a slightest abnormality is noted, immediately check and repair the faulty parts.

Free play of the brake pedal should be adjusted to be about 5~10 mm and to have enough effective travel. Excessive or deficient play decreases the efficiency of the brake. Good drivers keep their foot off the pedal when travelling

GASOLINE SUPPLY

The gasoline tank capacity is 25 liters. The amount

of gasoline can be ascertained by referring to the fuel gauge.

Checking for gasoline leakage is important not only from the standpoint of keeping down expenses but also for preventing dangerous fires.

TIRE PRESSURE

Tire pressure effects not only the tire but also the steering efficiency as well, and may even at worst become the cause of accidents, this, therefore, requires close attention.

Checking of tire pressure should be made when the tire is not heated and before the car is operated.

Tire Size		Air Pressure kg/cm ² (lb/in ²)	
Front Wheel	5.00—12—4P.R	1.4 (20)	
Rear Wheel	5.00—12—6P.R	Light Load	2.1 (30)
		Pay Load	3.1 (45)



OVER INFLATION

Hard Ride, Poor
Traction, Fabric
Breaks

UNDER INFLATION

Runs Hot, Loosens
Cords, Blowouts,
Uneven Wear



PROPER INFLATION

Good Ride, Good
Traction, Even Wear,
More Mileage

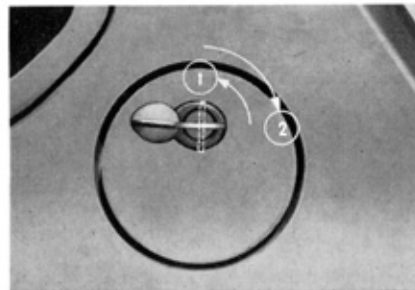

Description of the Mechanism (DELUXE)

h Fog Lamp Switch.....F

Pull this switch to light the fog lamp in case the beams of headlights do not afford sufficient visibility on account of dense fog or heavy rain. The penetrating yellow light will widen your field of vision for safe driving.

h Cigar Lighter.....CL

Push the lighter knob in all the way. In about 10 seconds, the lighter will automatically pop out to its normal position. Pull the lighter out of the socket to use it.

Car Heater

The car heater is located under the center section of the dashboard.

Heater Switch.....H

This switch is for regulating the revolution of fan housed in the heater.

Air Valve.....A

Pull the heater switch out and set valve to FRESH ① to obtain warm air. By setting the valve to RECIRCLE ② outside air to the heater will be blocked, and the interior air will circulate, and rapidly raise the interior temperature. Set the valve between RECIRCLE and FRESH for both functions.

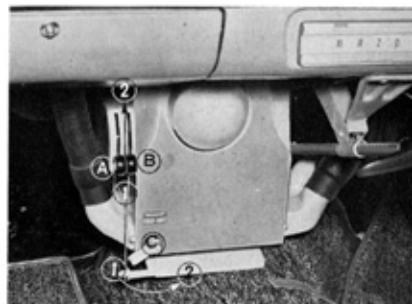
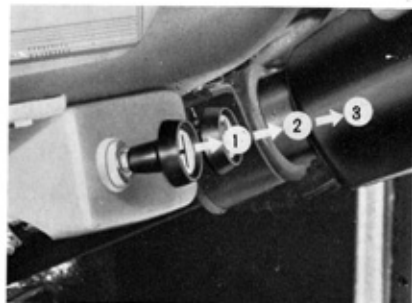

Room Valve.....B

Flow of hot air is provided from the lower part of car heater by pulling the heater switch and setting the valve to ROOM ①. In case of windshield fogging, set the valve to DEMIST ②. Setting the valve between ROOM and DEMIST will release the hot air from both the lower part of heater and demister nozzle. In this case proper adjustment should be made.

Water cock.....C

This cock is for regulating the volume of hot water in the heater. Setting the cock to COLD ① will shut off the water flow, whereas setting it to HOT ② will open the flow. Regulate the temperature by means of the heater switch and this cock.

Cautions on using Heater

This car heater is of hot-water type, so put it into use after the engine is warmed up. If the pointer of the thermometer indicates between H and C, it is proper.

When using a car heater, open an outlet valve (A) and inlet valve (B) of the engine for warm water. Close the valves (A) and (B) when the heater is not in use.

At the time of changing anti-corrosive agent or anti-freeze, be sure to open the channel by setting the abovementioned valves, (A) and (B), and the water cock to HOT so as to clean inside of the heater thoroughly.

Wiper Switch (Deluxe)

The wiper blades will work by pulling the wiper switch with the engine switch turned one step. The wiper works on 2 speeds, fast and slow. The first position of the wiper switch is for fast speed and the second for slow.

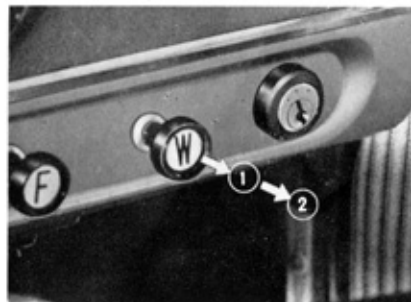

Directions for Using Window Washer

Turn the wiper clockwise lightly and release it then cleaner liquid will squirt on the windshield glass for about four or five seconds and stop automatically. Avoid using the wiper in dusting off dry windshield as this will cause scratches.

Front Seat

The adjustable bench type seat can be positioned as desired as it can be set at seven positions forward and rearward with adjust lever, located in the center front part of the front seat, being pulled clockwise. Press down the back rest of front seat to obtain wide space for easy access to the rear seat. To recline the back seat of left front seat, push down the button on the upper part of the back rest, while pressed.

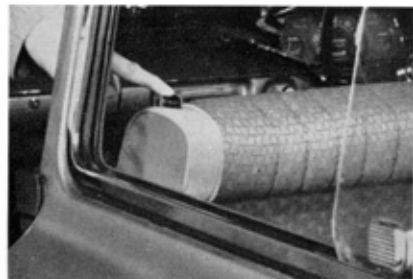

Rear Seat

When folding rear seat, hold the belt provided on the back side of the rear seat and raise the rear side of seat. Then, release the lock device provided on the left and right sides of the back rest of the rear seat and push forwardly the upper portion of the back rest. The seat will be partially housed in the floor for wide floor space.

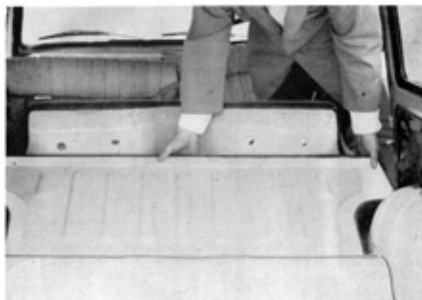

STARTING ENGINE



When the engine is started, push the choke button back little by little, and leave it where the engine runs smoothly for 2 or 3 minutes for warming-up.

As the engine gets warm, adjust the choke button to the normal idling, and when the engine is sufficiently warmed, push back the choke button completely. If the choke valve is in a close state, this will increase fuel

STARTING A COLD ENGINE

Turn the engine switch 1 turn to the right.

The electric fuel pump will be actuated and will begin feeding gasoline to the carburettor.

Make sure the generator warning lamp and oil pressure warning lamp are on.

Adjust the choke button according to the atmospheric temperature. When the temperature is very low, pull the choke button to its fullest extent.

The choke valve and the throttle valve are connected with a link, and when the choke button is pulled, the throttle valve is opened to make the engine start easily. Therefore, do not tread the accelerator pedal.

Depress the clutch pedal and turn on the starting switch.

consumption and premature wearing. Therefore, do not forget to push back the choke button.

When it is difficult to start the engine, the starting switch should not be engaged for more than 10 seconds. In such a case, allow an interval of 5 seconds before re-engaging the starting switch. Continuous use of the starter will cause an extreme drain of the battery. If starting is difficult, a check be made on the fuel system or the ignition system.

STARTING A WARM ENGINE

For starting when the engine is warm, just depress the accelerator pedal slightly, there is no need to use the choke button.

After the engine is started, check the engine revolution, exhaust gas, oil pressure (confirm that the warning lamp is off), and generator (confirm that warning lamp is off).

When the engine fails to start due to excessive suction, depress the accelerator pedal all the way down. Release the pedal as soon as the engine starts.

STARTING A CAR

Observe warming up. Wait until the engine is sufficiently warmed up before starting off.

Depress the clutch pedal while regulating the low engine speed with the accelerator pedal, and shift the gear shift lever slowly to low gear. Depress the clutch pedal once more in case of difficulty in shifting.

Depress the brake pedal and release the hand brake.

Release the brake pedal and accelerating the engine speed with the accelerator pedal, to suit the road condition, and release the clutch pedal gradually. When the car starts moving, increase the speed. (At this time both of generator and oil pressure lamps should be extinguished.)

When the car has gained speed, depress the clutch pedal and simultaneously release the accelerator pedal. Shift to second gear positively and release the clutch pedal, and at the same time depress the accelerator pedal. In the same way, shift to 3rd and top gears. And the speed can be controlled freely by the accelerator pedal alone.

CRUISING

When shifting down from top to third, from third to second, and second to low, this can be done by merely depressing the clutch pedal as they are synchromeshed, and there is no need for double-clutching. On curved roads, speed should be regulated according to the condition of the curve. Since the rear wheels have a smaller turning radius as compared to the front wheels, allowance should be made for the rear wheels when making a curve. Do not depress the accelerator pedal abruptly on curves.

In thick fog, it is taboo to speed up or to overtake other cars. It is also advisable to travel slowly and to sound your horn or switch on the head lamps to signal your existence.

Braking distance varies with the condition of the road. It should also be borne in mind that the braking distance will increase as the speed increases.

HILL CLIMBING

When approaching a hill or when driving on hilly roads, it is advisable to make the best use of inertia.

In case speed should gradually decrease, the gear

should be shifted down one step lower to suit the grade.

When starting on a grade after once stopping your car, bring your car to a complete stop by applying the hand brake, and then depress the clutch and shift to low gear.

Next, increase the engine revolution by depressing the accelerator pedal gently, gradually release the clutch pedal, also release the hand brake, and depress the accelerator pedal, and when the car begins to move, release the clutch pedal and the hand brake completely.

When parking on a grade, always turn front wheels toward the curb and shift to low gear. Do not forget to pull up the hand brake.

DESCENDING

When descending an incline, apply engine brake by shifting to the gear most suited to the condition of the grade. Applying the foot brake often will burn and damage the lining.

Engine brake is applied when going downhill by arranging the engine revolution to the lowest range. But it should be remembered never to switch off the

ignition; otherwise, unburned gasoline will enter the crankcase and dilute the oil, thereby will increase the wear of various parts.

REVERSING

First, make sure there is no obstacle behind the car.

Be sure the car has come to a complete standstill before you shift to reverse; otherwise, the gear may be damaged.

The reverse is the same as with starting off forward but it should be done slowly to avoid causing an accident.

STOPPING AND PARKING

For stopping the car, release the accelerator pedal before reaching the goal and depress the brake pedal gently.

Depress the clutch pedal when the car speed has dropped and is about to come to a stop. When the car has come to a complete stop, shift the gear lever to neutral and pull up the hand brake to make sure the car will not roll.

When leaving the car, make sure the engine is off, and also be sure to take the key along with you.

INSTRUCTIONS DURING COLD WEATHER

Low temperature in winter season makes starting difficult and tends to cause damage. Exercise caution on the following points.

STARTING THE ENGINE

The engine should be warmed up in advance.

Be sure to depress the clutch pedal when starting the engine.

Use the specified oil. (Cf. section on Oil)

In winter season the oil may be diluted by mixing with gasoline and accordingly requires earlier changing.

Performance of the storage battery will be decreased when the temperature falls. As the current needed for starting is reduced even in a fully charged state. Be careful not to leave the battery in a discharged condition, because it will not only make starting impossible but will cause the electrolyte to freeze which may result in the cracking of the battery case.

COOLING SYSTEM

In winter, the coolant may freeze and thus damage the cylinder block and radiator. Therefore, we recom-

mend that **MAZDA genuine anti-freeze** solution be used.

If anti-freeze solution is not used, drain the water while hot by removing the radiator cap and opening the drain cock before leaving the vehicle in the garage.

“MAZDA” GENUINE ANTI-FREEZE SOLUTION

It is very convenient to use anti-freeze solution in winter, because it will free you from worrying. We recommend that permanent type (P. T.) MAZDA genuine anti-freeze solution be used. This solution is stable and will be effective for the whole winter. It is also mixed with rust inhibitor and anti-oxidant.

Preparation before using anti-freeze solution.

Completely drain the coolant from the cooling system and wash off scale and rust with clean water or radiator cleaner. Check the cooling system for leakage and repair any leaks.

Instruction for filling the cooling system.

Coolant mixture...Use tap water (soft water) for mixing anti-freeze solution.

Mixing rate.....The mixing rate of the anti-freeze solution and water should be mixed

anticipating the coolant not to freeze even if the temperature gets 5 degrees lower than the lowest temperature.

(Note that mixture percentage is different for each brand of anti-freeze solution.)

Note that the effectiveness of the anti-freeze will be reduced if the concentration of anti-freeze solution is higher than the prescribed in after-mentioned table.

The mixture percentage for MAZDA genuine anti-freeze solution is as indicated in the following table.

Freezing Point (Centigrade)	Mixture Percentage (Volume)		Specific Gravity of Mixture (at 20°C)
	Anti-freeze Solution	Water	
- 3.6	10	90	1.015
- 6.5	15	85	1.022
- 9.0	20	80	1.029
-12.5	25	75	1.037
-16.0	30	70	1.044
-20.5	35	65	1.051
-25.6	40	60	1.058
-32.0	45	55	1.066
-38.5	50	50	1.073

For example, when the lowest temperature at the place where the vehicle is operated is expected to be -10°C , the mixing rate should be aimed at -15°C . In this case, use mixture percentage for -16°C in the table.

Amount: Pour in 4.1 liters of the mixture. Pour in 2 liters of the mixture first. Then pour in the engine, and the air will be expelled quickly.

Replenishment: Genuine anti-freezing solution is the permanent type and does not evaporate. Therefore, anti-freeze solution need not be added unless there is a leakage. However, since there will be loss of water through evaporation, check the coolant level daily and add water to make up for such a loss. Excessive supply of water in this case will lower the specific gravity of the mixture and reduce the effectiveness of the antifreezing solution. Therefore, check the consistency with a hydrometer from time to time. In case there is a loss of the solution through leakage, and the solution of the same specific gravity for such a loss should be replenished. Note that the effectiveness of the anti-freeze will be reduced if the consistency of anti-freeze solution is higher than prescribed in the afore-mentioned table.

Others

- Do not mix MAZDA genuine anti-freeze solution with other brands.
- When the winter season is over, there will be no need for anti-freeze. Drain the coolant and fill with tap water washing the system completely.

INSTRUCTION DURING HOT WEATHER

Extreme hot weather in the summer season may cause overheating. Your attention is called on the following points.

Check the shortage of coolant.

- Even a small leakage in the radiator will cause overheat. It should be repaired immediately.
- When the engine is overheated, stop the engine and slowly turn the cap (apply a piece of cloth) to its first stage. Checking the steam, out of boiling turn the cap slowly to its second stage a several minutes later. Pour in the coolant little by little.

Firmly tighten the radiator cap to its second stage.

- The fan belt has some slack, but excessive slack will cause slippage preventing proper revolution of the generator and the water pump, and will lead to over heat. Excessively tight belt will damage the belt and the bearings. As water and oil will severely affect the life of the belt, proper care should be taken.
- The proper slack of the belt is about 10 mm.

Pay attention to the level of electrolyte in the storage battery.

Constantly check the level of electrolyte and add distilled water if necessary, because the electrolyte tends to evaporate rapidly in extremely hot weather.

Avoid long time and high speed driving as much as possible. (Cf. section on Tires)

Be sure to use the specified oil.

You should also remember that, during the hot weather, accidents are often caused by intense fatigue.

Others

- Use soft water as coolant, and avoid using hard water (well water, hot spring water, and mineral water).

Absolutely avoid salt water. Anti-rust should be mixed with the coolant to prevent rust in the cooling system.

- In a long period of time, fur and other sediments will be deposited on the bottom of the water jacket and the radiator. As these will block the passage of the coolant and will prevent to radiating heat, the radiator should be cleaned **every 3 months** by opening the drain cock. It is advisable to use a radiator cleaner.

- As many parts of the engine are made from aluminum die-casting, **radiator cleaner** should be used.

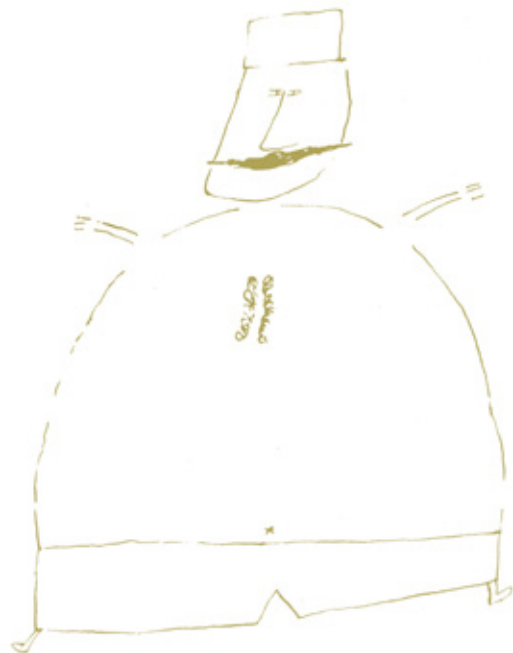

SUGGESTIONS FOR "BREAKING-IN" A NEW CAR

A car, however fine it may be, will never be able to display its full ability unless handled by a person fully acquainted with its mechanism as well as its performance. The life of a car is greatly affected by the kind of attention it receives when new. In spite of the fact that the quality of cars has been greatly elevated due to the progress made in production engineering, the need for "BREAK-IN" has been greatly reduced, you should give it a chance to "BREAK-IN" properly.

The car observing the following instructions during its first 1,000 km; will prevent mishap, will extend the life span of the car, and will be economical.

Conduct Warming up without fail.

When the pointer of the water temperature indicator goes above C (about 40°C), this means that the warming up is completed.

Do not perform racing immediately after starting the engine or during the warming up.

Refrain from high speed driving or sudden braking.

Do not overwork the engine by forcing operation at low speed.

Check for loose joints, and tighten if loose.

Refill with new engine oil.

No matter how smooth the sliding surface of a new car may be, minute particles of metal are apt to get mixed in the oil and circulate within the engine, thereby intensifying wear in the engine parts. The oil must therefore be drained every 500 km (300 miles) and refilled with fresh oil.

Replenishment of gear oil.

The transmission oil must be changed every 500 km (300 miles).

LIMITATION OF TOP SPEED

Excessive revolution of the engine during its break in period, and even after the break in period is bad for the engine. Therefore, the car should be carefully driven according to the following speed limit.

From 0 to 1,000 km (0-600 miles)

Low gear 15 km/h (9 mile/h)

2nd gear 25 km/h (16 mile/h)

3rd gear 45 km/h (28 mile/h)

After traveling over 1,000 km

Low gear 25 km/h (16 mile/h)

2nd gear 45 km/h (28 mile/h)

3rd gear 70 km/h (44 mile/h)

These speed limits are marked on the speedometer.

ECONOMICAL DRIVING

The way you handle your car will have a great deal to do with economical driving. Fuel consumption is especially affected by the road as well as operating conditions. The following suggestions will be helpful in saving you unnecessary expenses.

Racing and sudden acceleration are harmful.

Fuel is wasted by depressing the accelerator pedal repeatedly, accelerating unnecessarily, racing the engine when starting off, or when cruising.

It is advisable to operate your car in the economical speed range instead of in the high speed range.

It does not mean that high speed driving will require more fuel and extremely low speed will, on the other hand, require less fuel. The most economical speed is 40 km/h at top speed. It is advisable to maintain this speed constantly as much as possible.

Employ inertia profitably and refrain from repeating sudden braking.

Applying the brake unnecessarily while driving means that you are speeding up more than necessary. Applying the brake often necessitates repeated acceleration, and not only wears out the brake mechanisms and tires but also increases fuel consumption and, all in all, will prove uneconomical.

Shift to the suitable gear as the occasion demands.

Because the load imposed on the engine is great on grades, sufficient driving power cannot be expected from higher gears. Shifting to a suitable lower gear in such cases means not merely increasing driving power but also results in preventing the engine from becoming fatigued. It also permits the engine to display its full power and also saves fuel.

Maintain standard tire pressure and select good roads.

Fuel consumption rate varies greatly according to the condition of the road—whether the road is paved or graveled or sloped. Poor or hilly roads are hard on cars and should be avoided as much as possible.

Do not abuse the choke.

Abuse of the choke will not only cause the increase of fuel consumption, but will also cause premature wear in the engine.

Always have engine and relevant parts adjusted properly.

The life span of the engine will be prolonged and accidents will be prevented as well by proper adjustment.

Switch off the engine for long stops.

It is more economical to stop the engine for long stops. Idling will consume a certain amount of fuel.

Clean the air Cleaner often.

(Cf. section of Air Cleaner)

Selection and changing of lubricating oil.

(Cf. section of Specified Oil)

Selection of the gasoline.

The quality of the gasoline used have an important effect on engine performance. This will make it important to try out and compare different brands of

gasoline before making a choice, instead of judging a brand merely for its octane and specific gravity values. Although there is no necessity for using a high octane gasoline, it should be remembered to adjust the ignition timing, should circumstances require its use. Otherwise its value would be half reduced.

Handling of tires.

To prevent damage and increased wear of the tires, the followings should be observed :

- Always maintain the prescribed inflation pressure.
- Avoid applying unnecessary sudden brakes.
- Fire and oil are detrimental to the tire.
- Avoid traveling with low inflation pressure and driving with high speed on a bad road, because they will elevate the temperature of the tire.
- When the tire pressure is increased by the elevation of temperature, lower the pressure by driving slow or cooling-off the tires.
- In order to equalize the wear of each tires, they should be exchanged at the interval of 3,000—5,000 km. The inflation pressure should be adjusted to the standard pressure when the tires are cool.

PERIODIC INSPECTION AND MAINTENANCE

Place of Inspection	mile										Place of Inspection	mile														
	300	1,000	2,000	3,000	4,000	6,000	8,000	10,000	12,000	14,000		16,000	18,000	20,000	300	1,000	2,000	3,000	4,000	6,000	8,000	10,000	12,000	14,000	16,000	18,000
	km											km														
	500	1,500	3,000	4,500	6,000	9,000	12,000	15,000	18,000	21,000	24,000	27,000	30,000	500	1,500	3,000	4,500	6,000	9,000	12,000	15,000	18,000	21,000	24,000	27,000	30,000
Change the engine oil	<input type="checkbox"/>	<input type="checkbox"/>	<input type="checkbox"/>	<input type="checkbox"/>	<input type="checkbox"/>	<input type="checkbox"/>	<input type="checkbox"/>	<input type="checkbox"/>	<input type="checkbox"/>	<input type="checkbox"/>	<input type="checkbox"/>	<input type="checkbox"/>	<input type="checkbox"/>	<input type="checkbox"/>	<input type="checkbox"/>	<input type="checkbox"/>	<input type="checkbox"/>	<input type="checkbox"/>	<input type="checkbox"/>	<input type="checkbox"/>	<input type="checkbox"/>	<input type="checkbox"/>	<input type="checkbox"/>	<input type="checkbox"/>	<input type="checkbox"/>	<input type="checkbox"/>
Change the transmission oil	<input type="checkbox"/>	<input type="checkbox"/>	<input type="checkbox"/>	<input type="checkbox"/>	<input type="checkbox"/>	<input type="checkbox"/>	<input type="checkbox"/>	<input type="checkbox"/>	<input type="checkbox"/>	<input type="checkbox"/>	<input type="checkbox"/>	<input type="checkbox"/>	<input type="checkbox"/>	<input type="checkbox"/>	<input type="checkbox"/>	<input type="checkbox"/>	<input type="checkbox"/>	<input type="checkbox"/>	<input type="checkbox"/>	<input type="checkbox"/>	<input type="checkbox"/>	<input type="checkbox"/>	<input type="checkbox"/>	<input type="checkbox"/>	<input type="checkbox"/>	<input type="checkbox"/>
Change the rear axle oil	<input type="checkbox"/>	<input type="checkbox"/>	<input type="checkbox"/>	<input type="checkbox"/>	<input type="checkbox"/>	<input type="checkbox"/>	<input type="checkbox"/>	<input type="checkbox"/>	<input type="checkbox"/>	<input type="checkbox"/>	<input type="checkbox"/>	<input type="checkbox"/>	<input type="checkbox"/>	<input type="checkbox"/>	<input type="checkbox"/>	<input type="checkbox"/>	<input type="checkbox"/>	<input type="checkbox"/>	<input type="checkbox"/>	<input type="checkbox"/>	<input type="checkbox"/>	<input type="checkbox"/>	<input type="checkbox"/>	<input type="checkbox"/>	<input type="checkbox"/>	<input type="checkbox"/>
Change the steering gear case oil	<input type="checkbox"/>	<input type="checkbox"/>	<input type="checkbox"/>	<input type="checkbox"/>	<input type="checkbox"/>	<input type="checkbox"/>	<input type="checkbox"/>	<input type="checkbox"/>	<input type="checkbox"/>	<input type="checkbox"/>	<input type="checkbox"/>	<input type="checkbox"/>	<input type="checkbox"/>	<input type="checkbox"/>	<input type="checkbox"/>	<input type="checkbox"/>	<input type="checkbox"/>	<input type="checkbox"/>	<input type="checkbox"/>	<input type="checkbox"/>	<input type="checkbox"/>	<input type="checkbox"/>	<input type="checkbox"/>	<input type="checkbox"/>	<input type="checkbox"/>	<input type="checkbox"/>
Inspect function of the front & rear shock absorbers	<input type="checkbox"/>	<input type="checkbox"/>	<input type="checkbox"/>	<input type="checkbox"/>	<input type="checkbox"/>	<input type="checkbox"/>	<input type="checkbox"/>	<input type="checkbox"/>	<input type="checkbox"/>	<input type="checkbox"/>	<input type="checkbox"/>	<input type="checkbox"/>	<input type="checkbox"/>	<input type="checkbox"/>	<input type="checkbox"/>	<input type="checkbox"/>	<input type="checkbox"/>	<input type="checkbox"/>	<input type="checkbox"/>	<input type="checkbox"/>	<input type="checkbox"/>	<input type="checkbox"/>	<input type="checkbox"/>	<input type="checkbox"/>	<input type="checkbox"/>	<input type="checkbox"/>
Change the brake & clutch fluid	<input type="checkbox"/>	<input type="checkbox"/>	<input type="checkbox"/>	<input type="checkbox"/>	<input type="checkbox"/>	<input type="checkbox"/>	<input type="checkbox"/>	<input type="checkbox"/>	<input type="checkbox"/>	<input type="checkbox"/>	<input type="checkbox"/>	<input type="checkbox"/>	<input type="checkbox"/>	<input type="checkbox"/>	<input type="checkbox"/>	<input type="checkbox"/>	<input type="checkbox"/>	<input type="checkbox"/>	<input type="checkbox"/>	<input type="checkbox"/>	<input type="checkbox"/>	<input type="checkbox"/>	<input type="checkbox"/>	<input type="checkbox"/>	<input type="checkbox"/>	<input type="checkbox"/>
Clean the air cleaner	<input type="checkbox"/>	<input type="checkbox"/>	<input type="checkbox"/>	<input type="checkbox"/>	<input type="checkbox"/>	<input type="checkbox"/>	<input type="checkbox"/>	<input type="checkbox"/>	<input type="checkbox"/>	<input type="checkbox"/>	<input type="checkbox"/>	<input type="checkbox"/>	<input type="checkbox"/>	<input type="checkbox"/>	<input type="checkbox"/>	<input type="checkbox"/>	<input type="checkbox"/>	<input type="checkbox"/>	<input type="checkbox"/>	<input type="checkbox"/>	<input type="checkbox"/>	<input type="checkbox"/>	<input type="checkbox"/>	<input type="checkbox"/>	<input type="checkbox"/>	<input type="checkbox"/>
Change with new element of the air cleaner	<input type="checkbox"/>	<input type="checkbox"/>	<input type="checkbox"/>	<input type="checkbox"/>	<input type="checkbox"/>	<input type="checkbox"/>	<input type="checkbox"/>	<input type="checkbox"/>	<input type="checkbox"/>	<input type="checkbox"/>	<input type="checkbox"/>	<input type="checkbox"/>	<input type="checkbox"/>	<input type="checkbox"/>	<input type="checkbox"/>	<input type="checkbox"/>	<input type="checkbox"/>	<input type="checkbox"/>	<input type="checkbox"/>	<input type="checkbox"/>	<input type="checkbox"/>	<input type="checkbox"/>	<input type="checkbox"/>	<input type="checkbox"/>	<input type="checkbox"/>	<input type="checkbox"/>
Clean the gasoline strainer element	<input type="checkbox"/>	<input type="checkbox"/>	<input type="checkbox"/>	<input type="checkbox"/>	<input type="checkbox"/>	<input type="checkbox"/>	<input type="checkbox"/>	<input type="checkbox"/>	<input type="checkbox"/>	<input type="checkbox"/>	<input type="checkbox"/>	<input type="checkbox"/>	<input type="checkbox"/>	<input type="checkbox"/>	<input type="checkbox"/>	<input type="checkbox"/>	<input type="checkbox"/>	<input type="checkbox"/>	<input type="checkbox"/>	<input type="checkbox"/>	<input type="checkbox"/>	<input type="checkbox"/>	<input type="checkbox"/>	<input type="checkbox"/>	<input type="checkbox"/>	<input type="checkbox"/>
Change with new gasoline strainer element	<input type="checkbox"/>	<input type="checkbox"/>	<input type="checkbox"/>	<input type="checkbox"/>	<input type="checkbox"/>	<input type="checkbox"/>	<input type="checkbox"/>	<input type="checkbox"/>	<input type="checkbox"/>	<input type="checkbox"/>	<input type="checkbox"/>	<input type="checkbox"/>	<input type="checkbox"/>	<input type="checkbox"/>	<input type="checkbox"/>	<input type="checkbox"/>	<input type="checkbox"/>	<input type="checkbox"/>	<input type="checkbox"/>	<input type="checkbox"/>	<input type="checkbox"/>	<input type="checkbox"/>	<input type="checkbox"/>	<input type="checkbox"/>	<input type="checkbox"/>	<input type="checkbox"/>
Clean oil filter element	<input type="checkbox"/>	<input type="checkbox"/>	<input type="checkbox"/>	<input type="checkbox"/>	<input type="checkbox"/>	<input type="checkbox"/>	<input type="checkbox"/>	<input type="checkbox"/>	<input type="checkbox"/>	<input type="checkbox"/>	<input type="checkbox"/>	<input type="checkbox"/>	<input type="checkbox"/>	<input type="checkbox"/>	<input type="checkbox"/>	<input type="checkbox"/>	<input type="checkbox"/>	<input type="checkbox"/>	<input type="checkbox"/>	<input type="checkbox"/>	<input type="checkbox"/>	<input type="checkbox"/>	<input type="checkbox"/>	<input type="checkbox"/>	<input type="checkbox"/>	<input type="checkbox"/>
Change with new-oil filter element	<input type="checkbox"/>	<input type="checkbox"/>	<input type="checkbox"/>	<input type="checkbox"/>	<input type="checkbox"/>	<input type="checkbox"/>	<input type="checkbox"/>	<input type="checkbox"/>	<input type="checkbox"/>	<input type="checkbox"/>	<input type="checkbox"/>	<input type="checkbox"/>	<input type="checkbox"/>	<input type="checkbox"/>	<input type="checkbox"/>	<input type="checkbox"/>	<input type="checkbox"/>	<input type="checkbox"/>	<input type="checkbox"/>	<input type="checkbox"/>	<input type="checkbox"/>	<input type="checkbox"/>	<input type="checkbox"/>	<input type="checkbox"/>	<input type="checkbox"/>	<input type="checkbox"/>
Inspect the front wheel alignment	<input type="checkbox"/>	<input type="checkbox"/>	<input type="checkbox"/>	<input type="checkbox"/>	<input type="checkbox"/>	<input type="checkbox"/>	<input type="checkbox"/>	<input type="checkbox"/>	<input type="checkbox"/>	<input type="checkbox"/>	<input type="checkbox"/>	<input type="checkbox"/>	<input type="checkbox"/>	<input type="checkbox"/>	<input type="checkbox"/>	<input type="checkbox"/>	<input type="checkbox"/>	<input type="checkbox"/>	<input type="checkbox"/>	<input type="checkbox"/>	<input type="checkbox"/>	<input type="checkbox"/>	<input type="checkbox"/>	<input type="checkbox"/>	<input type="checkbox"/>	<input type="checkbox"/>
Grease each required point	<input type="checkbox"/>	<input type="checkbox"/>	<input type="checkbox"/>	<input type="checkbox"/>	<input type="checkbox"/>	<input type="checkbox"/>	<input type="checkbox"/>	<input type="checkbox"/>	<input type="checkbox"/>	<input type="checkbox"/>	<input type="checkbox"/>	<input type="checkbox"/>	<input type="checkbox"/>	<input type="checkbox"/>	<input type="checkbox"/>	<input type="checkbox"/>	<input type="checkbox"/>	<input type="checkbox"/>	<input type="checkbox"/>	<input type="checkbox"/>	<input type="checkbox"/>	<input type="checkbox"/>	<input type="checkbox"/>	<input type="checkbox"/>	<input type="checkbox"/>	<input type="checkbox"/>
Inspect the looseness of front, rear wheel bearings bolts and nuts of body	<input type="checkbox"/>	<input type="checkbox"/>	<input type="checkbox"/>	<input type="checkbox"/>	<input type="checkbox"/>	<input type="checkbox"/>	<input type="checkbox"/>	<input type="checkbox"/>	<input type="checkbox"/>	<input type="checkbox"/>	<input type="checkbox"/>	<input type="checkbox"/>	<input type="checkbox"/>	<input type="checkbox"/>	<input type="checkbox"/>	<input type="checkbox"/>	<input type="checkbox"/>	<input type="checkbox"/>	<input type="checkbox"/>	<input type="checkbox"/>	<input type="checkbox"/>	<input type="checkbox"/>	<input type="checkbox"/>	<input type="checkbox"/>	<input type="checkbox"/>	<input type="checkbox"/>

MAINTENANCE

FUEL SYSTEM

AIR CLEANER

If dust should enter the engine with intake gas, it will cause undue wear of various parts of the engine. In the air cleaner, the air is cleaned by passing through the air cleaner element before it is supplied to the carburettor. Accordingly, the air cleaner greatly affects the life of the engine. It is important, therefore, to remove and disassemble the air cleaner periodically and use low pressure compressed air line or soft brush, clean between the folds of the element. Or exchange with new as follows :

Air cleaner element must be cleaned-out every 3,000 km (2,000 miles). The element must be exchanged with new one at every 9,000 km (6,000 miles).

Important: Under dusty or sandy conditions it will be necessary to clean the element more frequently.

In winter time, especially when the atmospheric temperature is low, switch the lever to "winter" so that hot air will suck in the air cleaner, and the performance will rise. When the atmospheric temperature is high, be sure that the lever is changed to "summer."



CARBURETTOR

IDLING ADJUSTMENT

Before adjusting the idling, it is necessary that compression pressure, valve tappet clearance, ignition timing are satisfactorily adjusted. When adjusting, be sure to check the engine is fully warmed up and the choke valve is open.

- Screwing in the idling adjusting screw (A) will give a thin mixture, and unscrewing it will give a thick mixture of gas. Engine speed is increased by screwing in the throttle adjusting screw (B), and decreased by loosening this screw.
- Loosen the idling screw about 2 turns from the fully-screwed position and screw in the throttle adjusting screw 2 to 3 turns. Start the engine.
- Loosen the throttle adjusting screw slowly and place throttle in the lowest position.
- Screw in the idling adjusting screw gradually until the engine begins to run steadily. Stop screwing in at this point and drop the engine speed by further unscrewing the throttle adjusting screw.
- Continue this operation until a balanced idling is obtained on four cylinders.
- Care should be taken not to screw in the idling adjusting screw too tightly, otherwise the tip may be damaged and may cause unsatisfactory operation. In case satisfactory idling cannot be obtained, it is necessary to check the engine or to see whether the slow jet is not loose or whether there is an oversupply of oil in the tank.

ADJUSTMENT OF ACCELERATING PUMP

- When the throttle valve is suddenly opened, air is drawn first and fuel from main nozzle tends to be delayed, because the specific gravity of fuel and air differs. Thus the mixture will become temporarily thin and to compensate for this the carburettor is equipped with an accelerating pump.

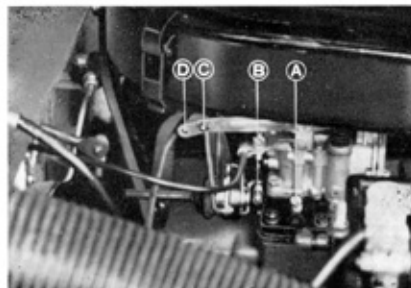

● On the top of the accelerator spindle rod there are two pin holes, which provide two changes in the accelerating injection amount. When the pin is placed in the C hole the injection amount is small, whereas the injection amount is large when the pin is placed in the D hole. Use D hole during the summer and C hole during the winter, depending on the condition of the engine and the atmospheric temperature.

ELECTRIC FUEL PUMP

When the ignition is switched on, the electric pump starts to work to feed fuel to the carburettor at a suitable pressure. This will facilitate starting the engine. If the fuel pump is out of order, the engine will, unlike in the case of fuel shortage, continuously make running noise and will be a cause for starting difficulty. So the cause must be checked into for.

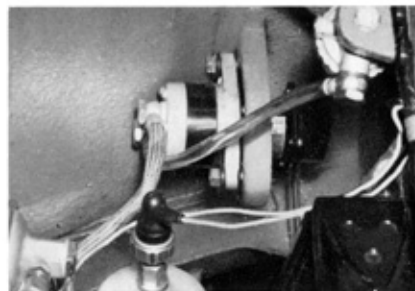

ADJUSTMENT OF VALVE CLEARANCE

When the engine is sufficiently warmed up (coolant temperature of over 70°C) adjust the tappets with a thickness gauge at 0.2 mm by adjusting screw (A) for both intake and exhaust valves. After adjustment has been completed, lock nut (B) must be sufficiently tightened to prevent looseness.

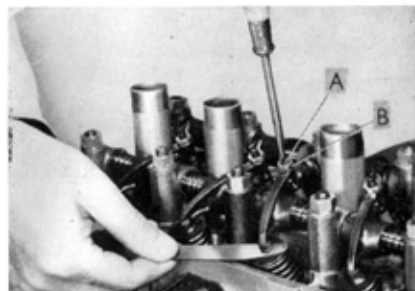

COOLING SYSTEM

Radiator

Check the coolant level and add with tap water (soft water) as coolant. When the winter season is over, and become to warm weather the anti-freeze is not necessary. But still using it will cause over-heat. Therefore, drain the coolant and fill with tap water after washing the cooling system completely. Even a slight leak of the radiator should be repaired immediately. Especially, the looseness of the hose bands must be checked. Besides, whenever the engine is hot, it should be required to take off the radiator cap. Turn cap to the 1st step and decrease the air pressure even to atmospheric pressure. After soon, turn the cap to the 2nd step and open.



Fan Belt

The fan belt has some slack, but excessive slack will cause slippage, preventing proper revolution of the generator and the water pump.

Excessively tight belt will damage the belt and the bearings. As water and oil will severely affect the life of the belt, proper care should be taken.

The belt tension should be adjusted so that the belt between generator and water pump can be depressed 10 mm with the fingertip.



BATTERY MAINTENANCE

A 12V, 32AH (20 hr.) battery is equipped on this car. The way in which you handle the battery will greatly effect not only its life span, but also the ignition and starting of the engine. It is important to keep the following points in mind in order to fully utilize its capacity.

- Care should be taken to keep the top of the battery, in particular, clean and dry.
- Fix the battery firmly on the car to prevent it from moving during travelling.
- The contact of the battery terminals should be checked and the wiring should be tightened.
- The battery terminal should be kept greased to prevent rust.
- The electrolyte should be checked and replenished with distilled water at all times.
- The specific gravity and voltage of the electrolyte should be checked from time to time to be sure they are in satisfactory conditions.
- Battery capacity is subject to the change of atmospheric temperature. As this is especially true in winter, care should be taken to keep it fully charged at all times.
- Charge the battery fully as soon as the specific gravity drops. But be careful before charge the battery must be removed from terminal connections (A) and (B).

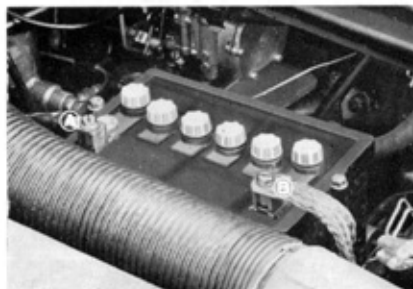

DISTRIBUTOR

Contact Point

The contact points close and open the primary circuit of the coil by cam action and thus induce high voltage in the secondary circuit of the coil. As dirty, burnt, and uneven points will cause unsatisfactory engine performance, the point should be removed, and ground evenly on oilstone and cleaned. If the points are severely burnt, replace with new ones.

Contact Point Adjustment

The contact point clearance should be adjusted to be 0.45 mm (0.018 inch) when completely opened by the cam. If the clearance is too small, poor starting, misfiring and burning of the points will result, while too large of clearance would result in misfiring at high speed and poor acceleration. Check the clearance periodically and adjust properly.

Procedure in Adjusting Clearance

Remove rotor and make the arm heel come to the highest point of the cam. Loosen set screw (A) of the ground point. Turn adjusting screw (B) and, by using a thickness gauge, obtain the proper clearance of 0.45 mm (0.018 inch). After making the adjustment, tighten set screw (A) firmly so it will not become loose. Re-check the clearance once again.

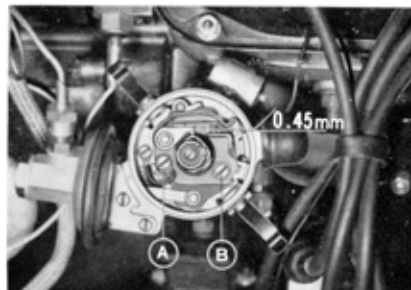

SPARK PLUGS

If on removal of the spark plug, the electrode is dry and brown, it indicates that the plug is satisfactory. When it is white, it is overheated, and when it is black, it indicates that some oil has flown up to the cylinder and the mixture is too rich.

- Select and use spark plugs best suited for the engine. The specified spark plug is N. G. K. C7 HWB.
- When the spark plug gap is too small, the spark will be small, causing difficulty in igniting the compressed gas. On the other hand, when the gap is too large, it would become difficult for the spark to jump the gap. Accumulation of carbon, faulty insulation, and cracks in the porcelain will cause misfiring.

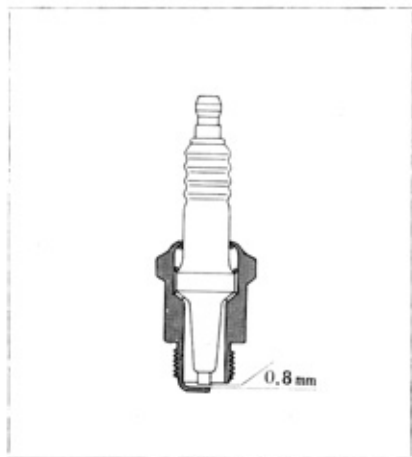

ELECTRICAL WIRING DIAGRAM

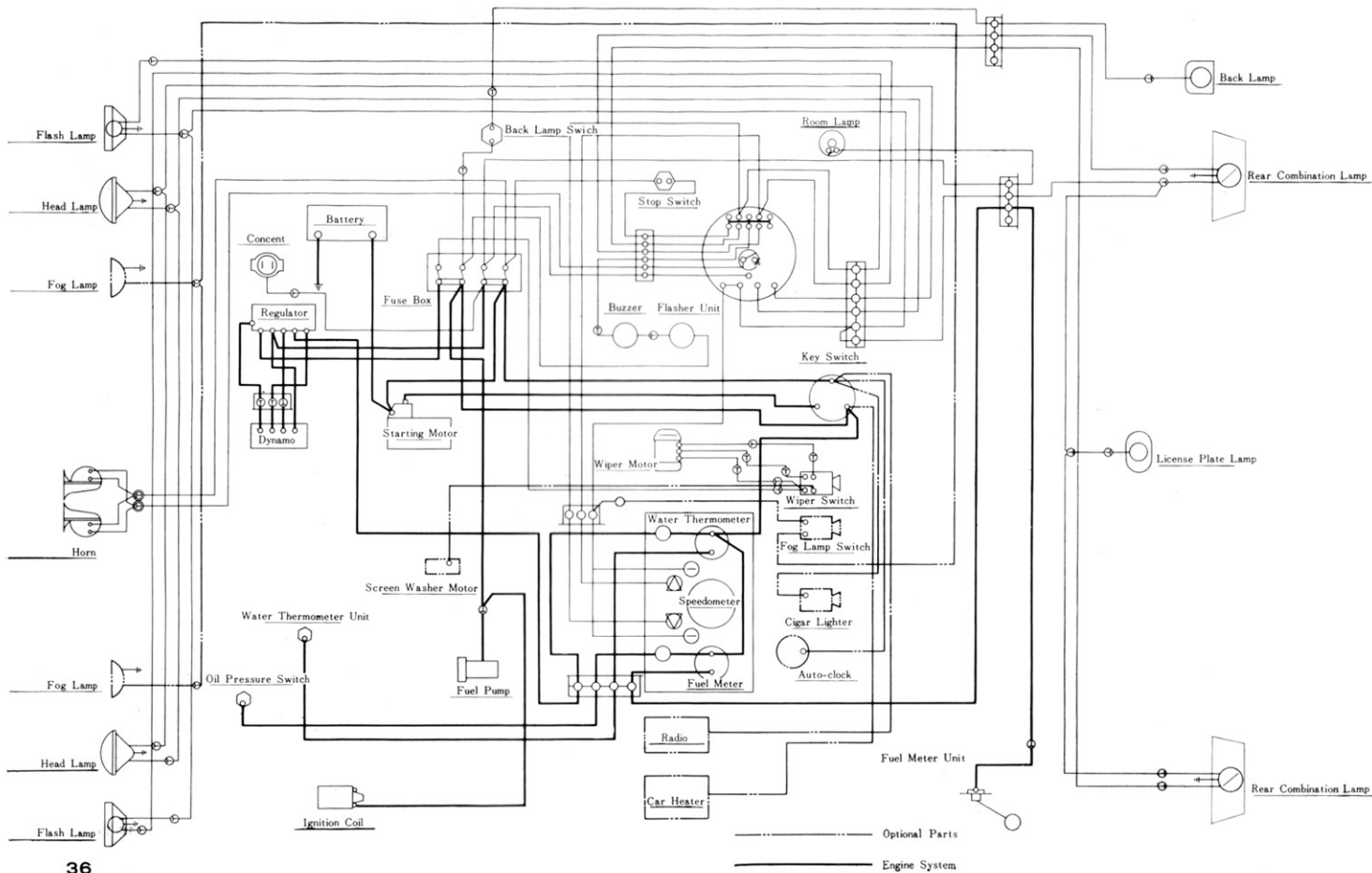

SPECIFIED OIL

Lubrication oil is important to the car, great care being necessary in its choice as well as in observing its exchange. The following chart should be referred to periodical lubrication. The engine oil, especially, is liable to be diluted with gasoline or to become fouled depending on the way the car is used and, therefore, should be changed when necessary, regardless of the distance travelled.

It should also be remembered to change to a suitable oil according to the variation in climate.

Lubrication Chart (Specified Lubricants)

Place of Lubrication		SAE Classification		Period of Oil Change
		Viscosity	Service	
Engine	30°C or over	SAE ⁴⁰ (20W—40)	MS	1st replacement 500 km (300 miles) 2nd replacement 1,500 km (1,000 miles) 3rd replacement and thereafter at every 3,000 km (2,000 miles)
	15°C or over	SAE ³⁰ (10W—30)	MS	
	-10°C or over	SAE ^{20 or 20W} (10W—30)	MS	
	-10°C or below	SAE ^{10W} (5W—20)	MS	
Transmission		SAE 90	Mild Type EP	1st replacement 500 km (300 miles) 2nd replacement 1,500 km (1,000 miles) 3rd replacement and thereafter at every 6,000 km (4,000 miles)
Rear Axle	Summer	SAE 140	Multipurpose	
	Winter	SAE 90		
Steering Gear Housing		SAE 90	—	1st replacement 6,000 km (4,000 miles) 2nd replacement and thereafter at every 15,000 km (8,000 miles)
Brake & Clutch Fluid		—	70 R ₃	every 9,000 km (6,000 miles)

SUPPLY ENGINE OIL

For supply engine oil the cap (A) should be unfastened and oil poured. When drain the oil, release the plug (B).



OIL PRESSURE

- When the lubrication oil is pressure fed to the engine by the oil pump, the oil pressure warning lamp will light off and assure you that it is being fed normally.
- The lamp does not go off, if either the oil pressure switch is faulty, the oil supply is low, the lubricating oil is unsatisfactory, or circulation is poor. Immediate care is necessary in such cases, otherwise wear or seizure of the various engine parts will take place.
- Should there be any abnormal or doubtful sign in the oil pressure, the engine must never be run for long and the car must not be operated.

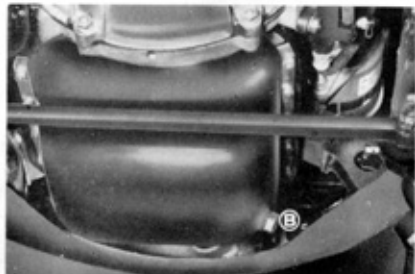

OIL FILTER

- Before the oil in the oil pan is supplied to the various parts of the engine it passes through the filter where it is filtered. As a high quality filter paper is used for the oil filter element, it removes all sediment etc., which causes early wear and damage. As a protective measure, 1st replacement of the oil filter should be replaced at 500 km (300 miles) and thereafter every 9,000 km (6,000 miles).
- If the amount of oil passing through the element should be clogged, the

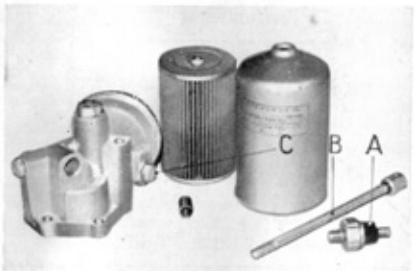

relief valve will open to permit direct flow, so that there will be no deficiency in the oil flow amount. However, as unfiltered oil will be circulated, it is cautioned that such oil will cause premature wear to the sliding parts.

- To replace the element, first remove the oil pressure switch (A) on the top of the filter, and next remove drain plug (C) and drain the oil. After draining the oil, remove the lock nut (B) and pull the filter case upward to remove.

- Use only genuine element.

- Before mounting the element, wash the inside of the case with gasoline. After replacing the element, run the engine for 2 or 3 minutes. As the oil filter will be filled with oil by doing this, check the oil level in the oil pan and replenish to the proper level.



SUPPLY TRANSMISSION OIL

When changing the oil, drain oil through the plug (D) below the transmission case and add oil from the gauge (C) located under the cover of the floor of the driver's room, oil level should stay within the red marking.

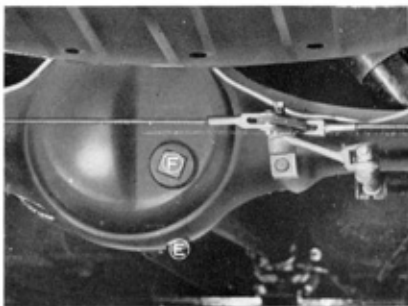

SUPPLY REAR AXLE OIL

When changing the oil, drain oil through the plug (E) and add oil from hole (F).



STEERING GEAR HOUSING OIL

Steering gear oil must be used SAE 90 (gear oil).
When changing the oil, supply the oil from the plug
(1).

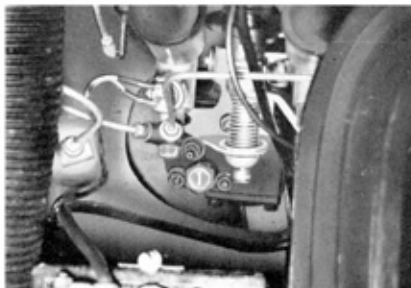

LUBRICATING POINTS

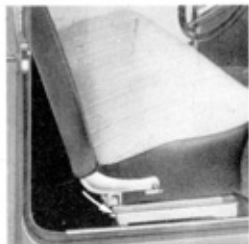

Front Seat Rail

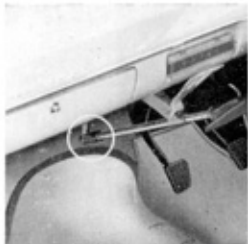

Hand Brake

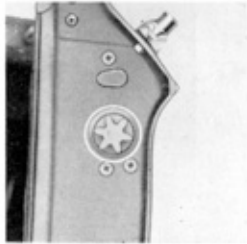

Door Lock



Door Hinge

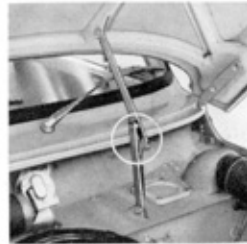

Bonnet Supporter



Back Door (Upper)

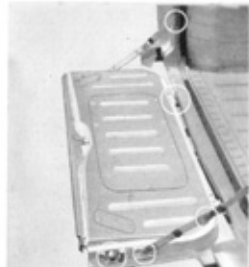

Back Door (Lower)

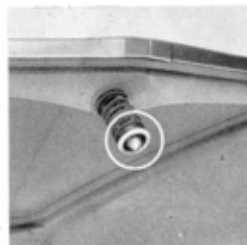

Bonnet Hook



Bonnet Lock

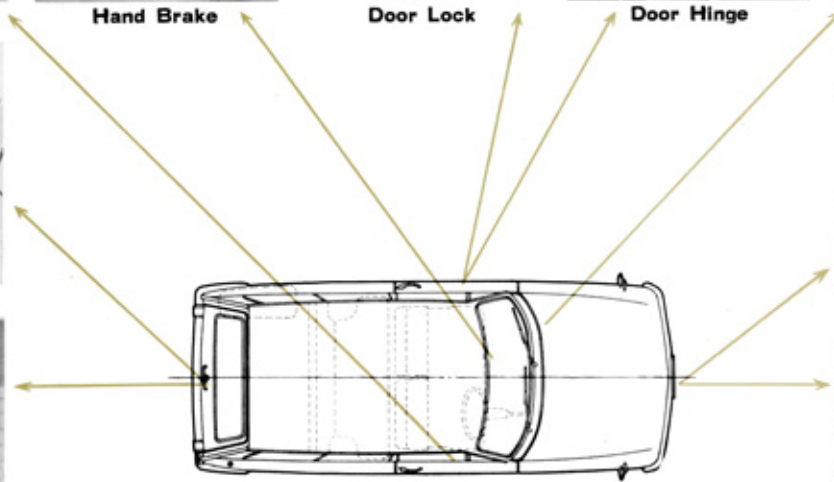

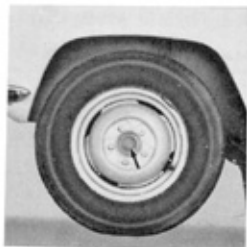

Front Wheel Bearing
 Wheel Bearing Grease
 Supply every 3,000km
 Change every 9,000km



Tie Rod Center Link
 Chassis Grease
 Supply every 6,000km

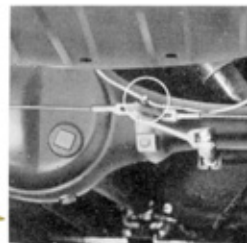

Hand Brake Equalizer
 Chassis Grease
 Supply every 1,000km

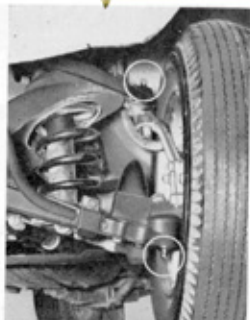
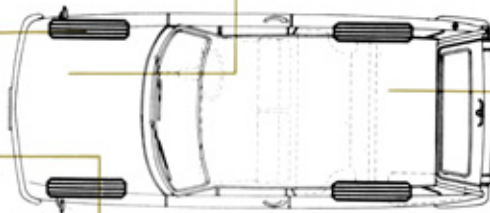

Upper & Lower Ball Joint
 Chassis Grease
 Supply every 6,000km



Chassis Grease
 Supply every 6,000km



Idler
 Chassis Grease
 Supply every 6,000km

CARE AND MAINTENANCE OF BODY

If the painted surface of the body is dirty, it will not only defile the fine appearance of your car, but will also not be preferable for the lasting quality of the paint finish.

Your daily care on the paint finish is important.

The stain on the paint finish will shorten its life, and all sorts of filth (soot, dust, sand and dirt, oil, moisture, etc.) will worsen the finish.

Therefore, it is very important to remove stains and keep the finish clean.

Keeping the finish clean is not only economical but will also save you from doing unnecessary repainting.

METHOD OF CARE

- When dusting off, use a soft cloth or a feather brush. Be careful not to scratch the finish.
- When dirt is on the finish, wash carefully with clean water.
- When soap water is used, do not forget to thoroughly wash it off with clean water.
- Dry the body either with pressure air, soft cloth or sponge, etc.
- When oil or grease is adhered, wipe it off with soap water or gasoline. Then thoroughly wash with clean water.
- When paint sticks on, it is important to immediately wipe it off lightly with a soft cloth dipped in gasoline.

When it is a fast drying paint (lacquer, etc.) it will dry even while it is being wiped. In this case, therefore, you should lightly rub it off with a compound.

- When the interior upholstery gets dirty, you can clean it as mentioned above. However, when wiping off paint, thinner or gasoline should be used.

Some of the materials used in the interior upholstery may change color or shrink, so it is necessary to first try wiping it where it does not stand out.

- When the rubber parts get dirty, avoid using gasoline or thinner. If you happen to use them, you should polish with wax or liquid silicon. Otherwise, this will cause cracks on the rubber.

- When the body is damaged, paint the damaged parts with the same color of lacquer. Coat it over and over after each coating is dried until the coating of the damaged part gets slightly higher than the undamaged surface. After the lacquer dries completely, lightly rub with a soft cloth pasted with compound. By doing this, you can obtain a neat finish.

- Although it depends on the largeness of the damage, it is advisable for you to temporarily paint the damaged parts in order to prevent rust even though you are intending to have it repainted.

- When the body gets covered with snow or frost, wash it with warm water and dry with soft cloth or sponge, as soon as possible.

- When the paint finish has different colored spots, this is presumably caused by adhesion of alkaline or acidic matters. For example, when soap water or

sweat dries on the paint finish, these spots occur. Most of these spots can be erased by lightly rubbing them with a soft cloth pasted with compound.

- After removing the stains as mentioned above, polish the body with wax or liquid silicon for cars.

METHOD OF MAINTENANCE

- Avoid using vinyl car cover during the summer season. Due to the summer heat, the vinyl might stick on the paint finish and ruin the fine appearance of your car. Therefore, it is wise to use a water-proof cloth or canvas for your car cover, which is most commonly used.

- Avoid exposure to rain as much as possible because it is bad for the paint finish. After your car is exposed to rain, it is necessary for you to take care of your car as soon as possible.

- When rust is on the body, rub the rust off with gasoline and paint it with the same color. When the same color of paint is not available, paint with transparent clear lacquer.

- If dirt is adhered to the underbody of the car, this will quicken rust. Wash with clean water and dry it.

WATER WASHING

- A feather duster may be used to dust the car, but frequent washing will bring out a more beautiful luster. When washing, start from the top and work downwards and avoid exposure to direct sunlight. Wipe off water completely with soft leather before it is dried.
- After the surface is dried, apply a small quantity of car polish lightly with a piece of cloth. Too much wax will not bring out a brilliant luster. On the other hand insufficient wax will shorten the life of the paint. A thin white coating should remain after the wax is dried.
- Before the dried wax turns to a white powder, thin out the wax with a steady horizontal stroke, always working toward the same direction. When the wax is sufficiently thinned out and begins to dry white, start polishing from one end and keep on working outwards.
- Dust off the chrome plated parts, and wash with soap and warm water. Dry it with chamois leather or soft cloth.

If the chrome plated parts are left wet after rain fall, spots will occur. In this case, wipe it with silicon oil. It is advisable to wipe the chrome plated parts with

silicon oil once a month to maintain brilliance and to prevent rust.

TROUBLE INDICATIONS

If engine does not start

If headlight is dim and engine does not run

Examine the battery to see whether it is not discharged.

Examine the terminal for looseness or corrosion.

If the gasoline is not being fed to the carburettor

Confirm the working condition of the fuel pump.

Look for defects or looseness in the pipe joints.

If the plug does not spark

The plug may be unclean or insulation may be poor.

Look for water on the distributor and coil.

The rotor or cap may be unclean or cracked.

The point may be unclean or burned.

The coil may be snapped or short-circuited.

The condenser may be deficient.

Look for other point where insulator may have become unsatisfactory or where short-circuit has occurred.

Others

Check the gasoline supply.

Look for water in gasoline.

Gasoline may have over flown from carburettor.

The compressed pressure may have dropped due to jumping up of valve.

If acceleration is poor and power is weak

The air cleaner may be clogged.

The ignition timing may have become retarded.

The gas mixture may be excessively rich.

The main jet of the carburettor may be clogged.

The brake may still be in an applied condition.

The silencer may be clogged.

The compressed pressure may have become low.

If knocking occurs

The car may be overloaded.

The gas mixture may be too thin.

The ignition timing may be too advanced.

The engine may be overheated.

The gasoline may be of poor quality.

The brake may still be in an applied condition.

Look for carbon deposits in combustion chamber.

Distributor advance may be unsatisfactory.

If the oil pressure warning lamp is lighted

- Check the oil to see if there is a sufficient supply.
- Air may be entering the pipe through the joints.
- The oil filter may be clogged.
- The lamp switch may be out of order.
- The oil may have become diluted with gasoline.
- Much oil may be leaking somewhere in the lubricating system.

If braking is not effective

- The drum and shoe may not have been satisfactorily adjusted.
- Water may have entered the drum.
- The lining surface may have become hardened.
- Air may have entered the pipe.

If there is a marked increase in gasoline consumption

- The choke may be closed.
- Ignition timing may be out of order.
- The air cleaner may be clogged.
- Tire pressure may be insufficient.

- The engine may be idling at high speed.
- Gasoline may be leaking somewhere.
- The brake may still be in an applied condition.
- The air breather in the carburettor may be clogged.

TOYO KOGYO CO.,LTD.

Main Office and Plant :

6047 Fuchu-machi, Aki-gun, Hiroshima, Japan

Tokyo Branch Office :

6, 3-chome, Nihonbashi-Edobashi, Chuōku, Tokyo, Japan

Osaka Branch Office :

17, 4-chome, Minami-kyuhoji-machi, Higashi-ku, Osaka, Japan

TOYO KOGYO CO.,LTD.